

### • General Description

AP3407B combines advanced MOSFET technology with a low resistance package to provide extremely low  $R_{DS(ON)}$ . This device is most suitable to load-switch or PWM applications.

### • Applications

- DC/DC converter for portable devices
- Load switch

### • Product Summary

$V_{DS}$ (V)	-30V
$I_D$	-4.1A
$R_{DS(ON)}$ (at $V_{GS} = -10V$ )	< 52m $\Omega$
$R_{DS(ON)}$ (at $V_{GS} = -4.5V$ )	< 87m $\Omega$

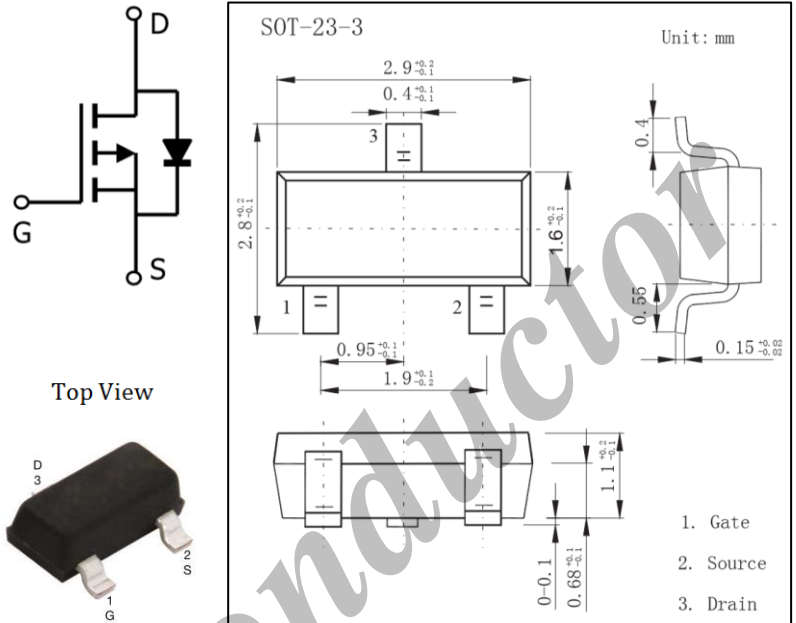

### • Absolute Maximum Ratings ( $T_a = 25^\circ\text{C}$ unless otherwise noted)

Parameter	Symbol	Rating	Unit
Drain-Source Voltage	$V_{DS}$	-30	V
Gate-Source Voltage	$V_{GS}$	$\pm 20$	V
Continuous Drain Current	$I_D$	$T_a = 25^\circ\text{C}$	-4.1
		$T_a = 70^\circ\text{C}$	-3.5
Pulsed Drain Current	$I_{DM}$	-20	A
Power Dissipation	$P_D$	$T_a = 25^\circ\text{C}$	1.4
		$T_a = 70^\circ\text{C}$	1
Thermal Resistance.Junction- to-Ambient	$R_{thJA}$	$t \leq 10s$	90
		Steady State	125
Thermal Resistance.Junction- to-Lead	$R_{thJL}$	60	$^\circ\text{C/W}$
Junction Temperature	$T_J$	150	$^\circ\text{C}$
Storage Temperature Range	$T_{stg}$	-55 to 150	$^\circ\text{C}$

• **Electrical Characteristics (Ta = 25°C unless otherwise noted)**

Parameter	Symbol	Test Conditions	Min	Typ	Max	Unit
Drain-Source Breakdown Voltage	V <sub>DSS</sub>	I <sub>D</sub> =-250 μ A, V <sub>GS</sub> =0V	-30			V
Zero Gate Voltage Drain Current	I <sub>DSS</sub>	V <sub>DS</sub> =-24V, V <sub>GS</sub> =0V			-1	μ A
		V <sub>DS</sub> =-24V, V <sub>GS</sub> =0V, T <sub>J</sub> =55°C			-5	
Gate-Body leakage current	I <sub>GSS</sub>	V <sub>DS</sub> =0V, V <sub>GS</sub> =±20V			±100	nA
Gate Threshold Voltage	V <sub>GS(th)</sub>	V <sub>DS</sub> =V <sub>GS</sub> I <sub>D</sub> =-250 μ A	-1	-1.8	-3	V
Static Drain-Source On-Resistance	R <sub>DS(on)</sub>	V <sub>GS</sub> =-10V, I <sub>D</sub> =-4.1A		40.5	52	m Ω
		V <sub>GS</sub> =-10V, I <sub>D</sub> =-4A T <sub>J</sub> =125°C		57	73	
		V <sub>GS</sub> =-4.5V, I <sub>D</sub> =-3A		64	87	
On state drain current	I <sub>D(ON)</sub>	V <sub>GS</sub> =-4.5V, V <sub>DS</sub> =-5V	-10			A
Forward Transconductance	g <sub>FS</sub>	V <sub>DS</sub> =-5V, I <sub>D</sub> =-4A	5.5	8.2		S
Input Capacitance	C <sub>iss</sub>	V <sub>GS</sub> =0V, V <sub>DS</sub> =-15V, f=1MHz		700		pF
Output Capacitance	C <sub>oss</sub>			120		
Reverse Transfer Capacitance	C <sub>rss</sub>			75		
Gate resistance	R <sub>g</sub>	V <sub>GS</sub> =0V, V <sub>DS</sub> =0V, f=1MHz		10		Ω
Total Gate Charge	Q <sub>g</sub>	V <sub>GS</sub> =-4.5V, V <sub>DS</sub> =-15V, I <sub>D</sub> =-4A		14.3		nC
Gate Source Charge	Q <sub>gs</sub>			7		
Gate Drain Charge	Q <sub>gd</sub>			3.1		
Turn-On DelayTime	t <sub>d(on)</sub>	V <sub>GS</sub> =-10V, V <sub>DS</sub> =-15V, R <sub>L</sub> =3.6 Ω, R <sub>GEN</sub> =3 Ω		8.6		ns
Turn-On Rise Time	t <sub>r</sub>			5		
Turn-Off DelayTime	t <sub>d(off)</sub>			28.2		
Turn-Off Fall Time	t <sub>f</sub>			13.5		
Body Diode Reverse Recovery Time	t <sub>rr</sub>			27		
Body Diode Reverse Recovery Charge	Q <sub>rr</sub>	I <sub>F</sub> =-4A, di/dt=100A/μ s		15		nC
Maximum Body-Diode Continuous Current	I <sub>S</sub>				-2.2	A
Diode Forward Voltage	V <sub>SD</sub>	I <sub>S</sub> =-1A, V <sub>GS</sub> =0V		-0.77	-1	V

• **Ordering Information**

Ordering Part Number	Package	MOQ
AP3407B	SOT23-3	3,000 pcs / reel

THIS PRODUCT HAS BEEN DESIGNED AND QUALIFIED FOR THE CONSUMER MARKET. APPLICATIONS OR USES AS CRITICAL COMPONENTS IN LIFE SUPPORT DEVICES OR SYSTEMS ARE NOT AUTHORIZED. APOLLO SEMICONDUCTOR DOES NOT ASSUME ANY LIABILITY ARISING OUT OF SUCH APPLICATIONS OR USES OF ITS PRODUCTS. APOLLO SEMICONDUCTOR RESERVES THE RIGHT TO IMPROVE PRODUCT DESIGN, FUNCTIONS AND RELIABILITY WITHOUT NOTICE.

• Typical Characteristics

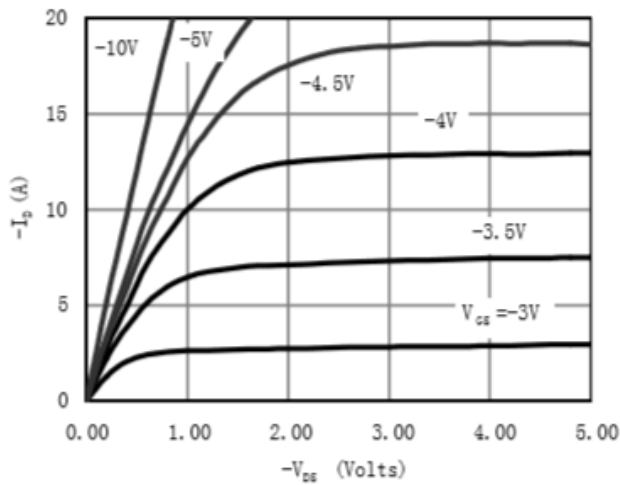

Figure 1: On-Region Characteristics

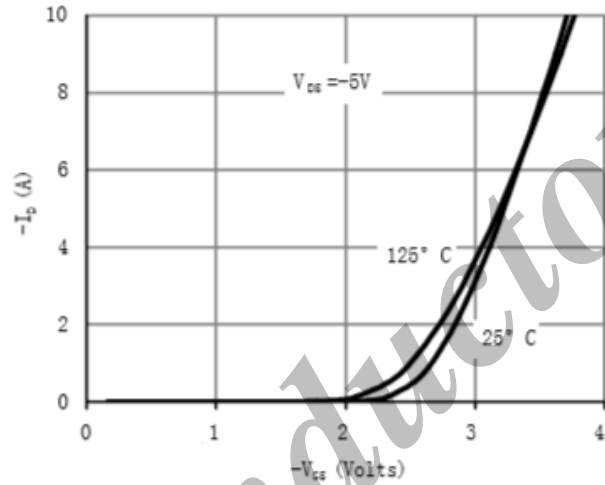

Figure 2: Transfer Characteristics

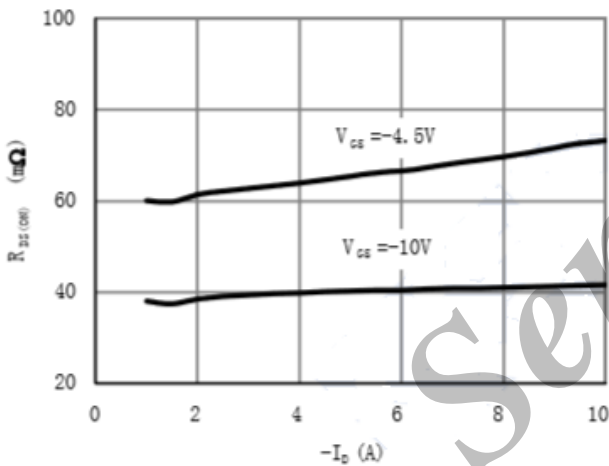

Figure 3: On-Resistance vs. Drain Current and Gate Voltage

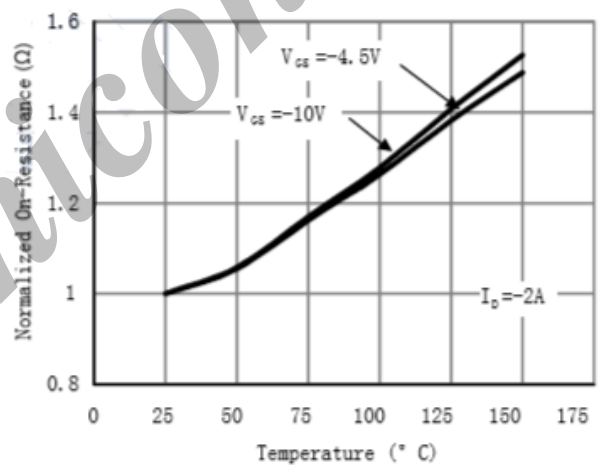

Figure 4: On-Resistance vs. Junction Temperature

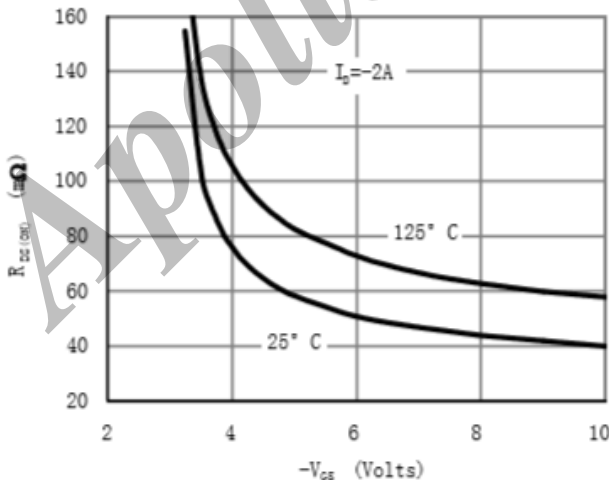

Figure 5: On-Resistance vs. Gate-Source Voltage

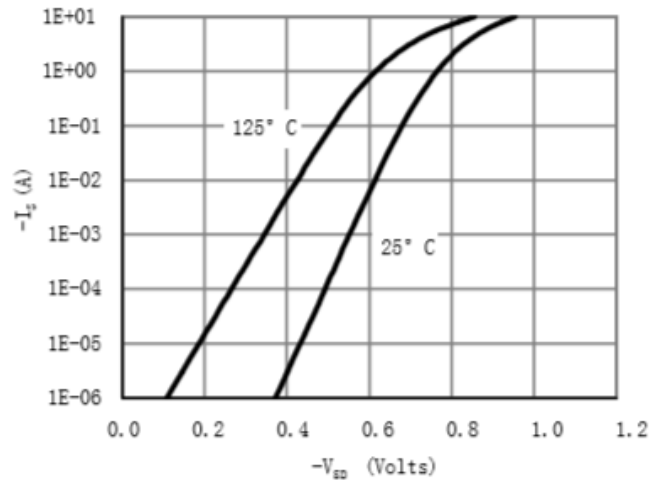

Figure 6: Body-Diode Characteristics

• **Typical Characteristics**

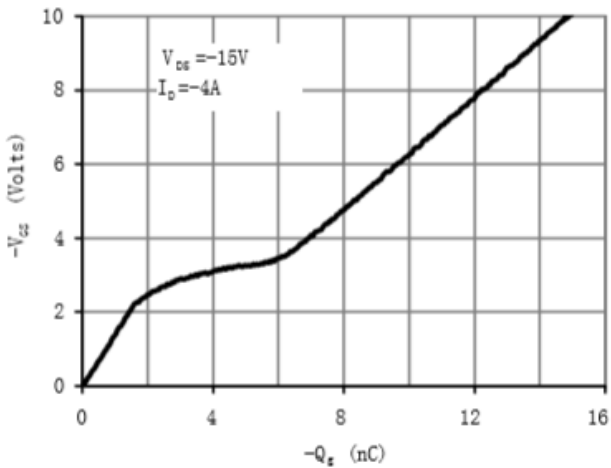

Figure 7: Gate-Charge Characteristics

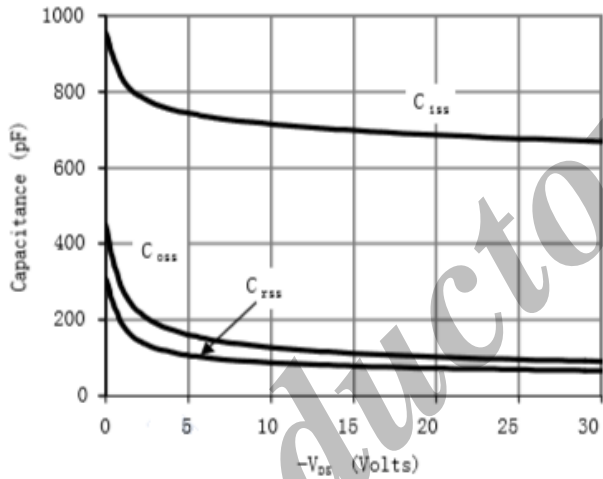

Figure 8: Capacitance Characteristics

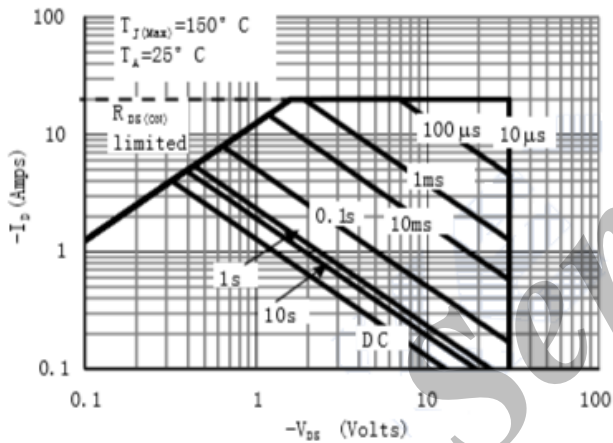

Figure 9: Maximum Forward Biased Safe Operating Area (Note E)

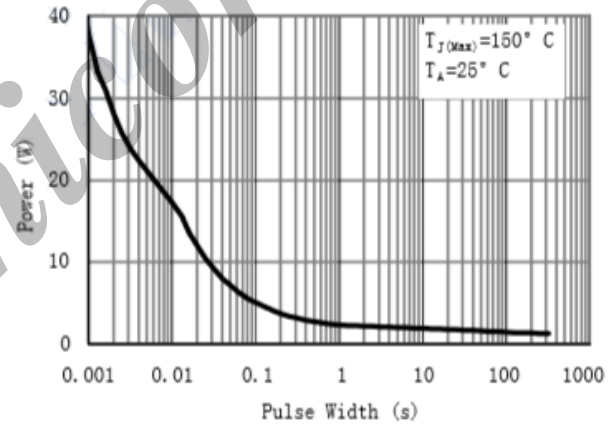

Figure 10: Single Pulse Power Rating Junction-to-Ambient (Note E)

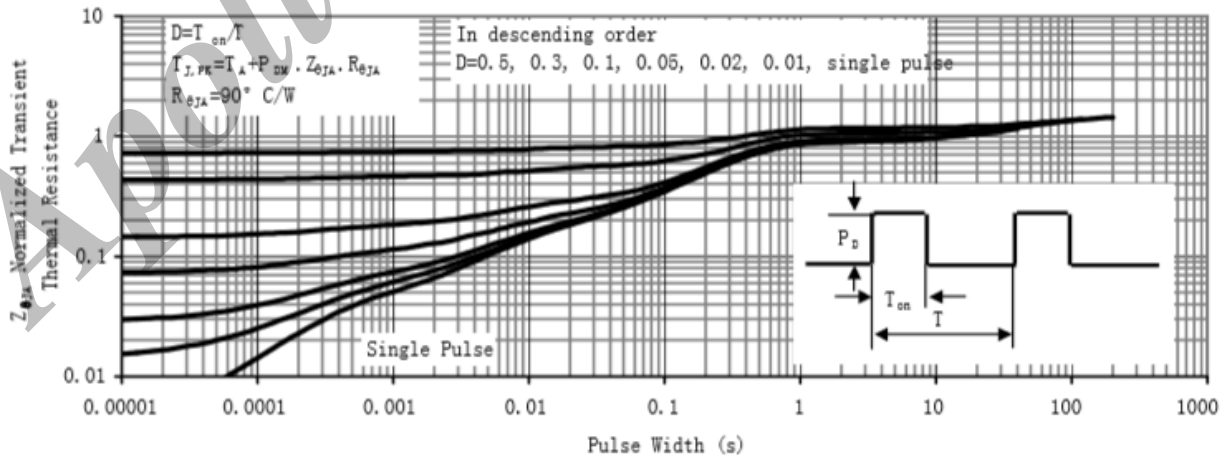

Figure 11: Normalized Maximum Transient Thermal Impedance

### Disclaimer

ALL PRODUCT, PRODUCT SPECIFICATIONS AND DATA ARE SUBJECT TO CHANGE WITHOUT NOTICE TO IMPROVE RELIABILITY, FUNCTION OR DESIGN OR OTHERWISE.

Apollo Semiconductor Ltd., its affiliates, agents, and employees, and all persons acting on its or their behalf (collectively, "Apollo"), disclaim any and all liability for any errors, inaccuracies or incompleteness contained in any datasheet or in any other disclosure relating to any product.

Apollo makes no warranty, representation or guarantee regarding the suitability of the products for any particular purpose or the continuing production of any product. To the maximum extent permitted by applicable law, Apollo disclaims (i) any and all liability arising out of the application or use of any product, (ii) any and all liability, including without limitation special, consequential or incidental damages, and (iii) any and all implied warranties, including warranties of fitness for particular purpose, non-infringement and merchantability.

Statements regarding the suitability of products for certain types of applications are based on Apollo's knowledge of typical requirements that are often placed on Apollo products in generic applications. Such statements are not binding statements about the suitability of products for a particular application. It is the customer's responsibility to validate that a particular product with the properties described in the product specification is suitable for use in a particular application. Parameters provided in datasheets and / or specifications may vary in different applications and performance may vary over time. All operating parameters, including typical parameters, must be validated for each customer application by the customer's technical experts. Product specifications do not expand or otherwise modify Apollo's terms and conditions of purchase, including but not limited to the warranty expressed therein.

Except as expressly indicated in writing, Apollo products are not designed for use in medical, life-saving, or life-sustaining applications or for any other application in which the failure of the Apollo product could result in personal injury or death. Customers using or selling Apollo products not expressly indicated for use in such applications do so at their own risk. Please contact authorized Apollo personnel to obtain written terms and conditions regarding products designed for such applications.

No license, express or implied, by estoppel or otherwise, to any intellectual property rights is granted by this document or by any conduct of Apollo. Product names and markings noted herein may be trademarks of their respective owners